



Installation instruction

Additional information about LegaMove can be found for download from the Hettich website www.hettich.com under Service / Media centre



Detailed operation instructions

All persons involved in the installation, maintenance or operation of this system should follow these instructions carefully.

Installation:

- The installation and operation of the desk frame have to be made in accordance with the installation and operating instructions to avoid the risk of injury.
- At installation and operation the generally applicable statutory and other rules and regulations of the country of operation as well as the applicable environmental regulations must be observed. The local applicable regulations of the professional associations or other supervisory authorities are to be observed.
- Electrical cables should not be exposed to crushing, bending and tensile stress.
- The socket outlet for connection to the mains supply must be installed by a licensed electrician to exclude hazards to persons and property.

Operation:

- The system is intended for use exclusively for height adjustable working desks in compliance with the specified maximum loads. Any other use is considered improper. The manufacturer is not liable for any resulting damage. The risk lies entirely with the user.
- The system should only be used in dry, dust-free areas without exposure to direct sunlight. Do not allow liquids to penetrate into the interior of the components, otherwise electric shocks or short circuits may result.
- The duty cycle is 10%, meaning 2 minutes „ON“ and 18 minutes „OFF“ or 1 minute „ON“ and 9 minutes „OFF“.
- Loads must not be exceeded.

Safety regulations:

- To avoid shearing, jamming and crushing, keep a minimum distance of 25mm towards body parts and objects.
- When adjusting the desk height, the user has to make sure that nobody will be injured and no object will be damaged. The desk must not collide with stationary objects so that the desk is not turning over.
- Do not let children unsupervised with this system. Children can not assess the threat posed by the force of the system.
- Never open any components of the system. Unauthorized opening and improper repairs could expose the user to risks and the warranty becomes void. Opening or repairing the electrical equipment must only be carried out by the staff of the manufacturer.
- Unauthorized modifications to the system exclude any liability of the manufacturer for any resulting damage.
- In case of malfunctions such as smoke or odor or unusual noise or visible external damage, the product must not be operated. Unplug the power cord.

Fulfilled standards:

2006/42/EG
 2014/30/EU
 2014/35/EU
 EN ISO 12100: 2011-03
 EN 349: 2008-09
 EN ISO 13857: 2008-06
 EN 60335-1: 2010
 EN 62233: 2008-11
 DIN EN ISO 13849-1 Category B, Performance Level b (2006)
 2011/65/EU (RoHS)
 1907/2006/EU (REACH)
 DIN EN 82079-1: 2013-06
 DIN EN ISO 7779: 2011-01
 AfPS GS 2014: 01 PAK
 EN 61000-6-2: 2006-03
 EN 61000-6-3: 2011-09
 EN 61000-3-2: 2014-08
 EN 61000-3-3: 2013

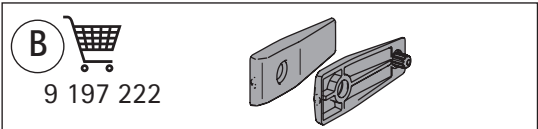
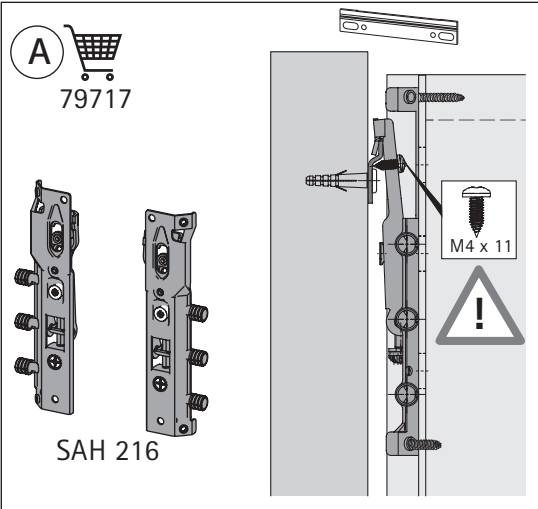

(Einbaubeispiel / installation example)

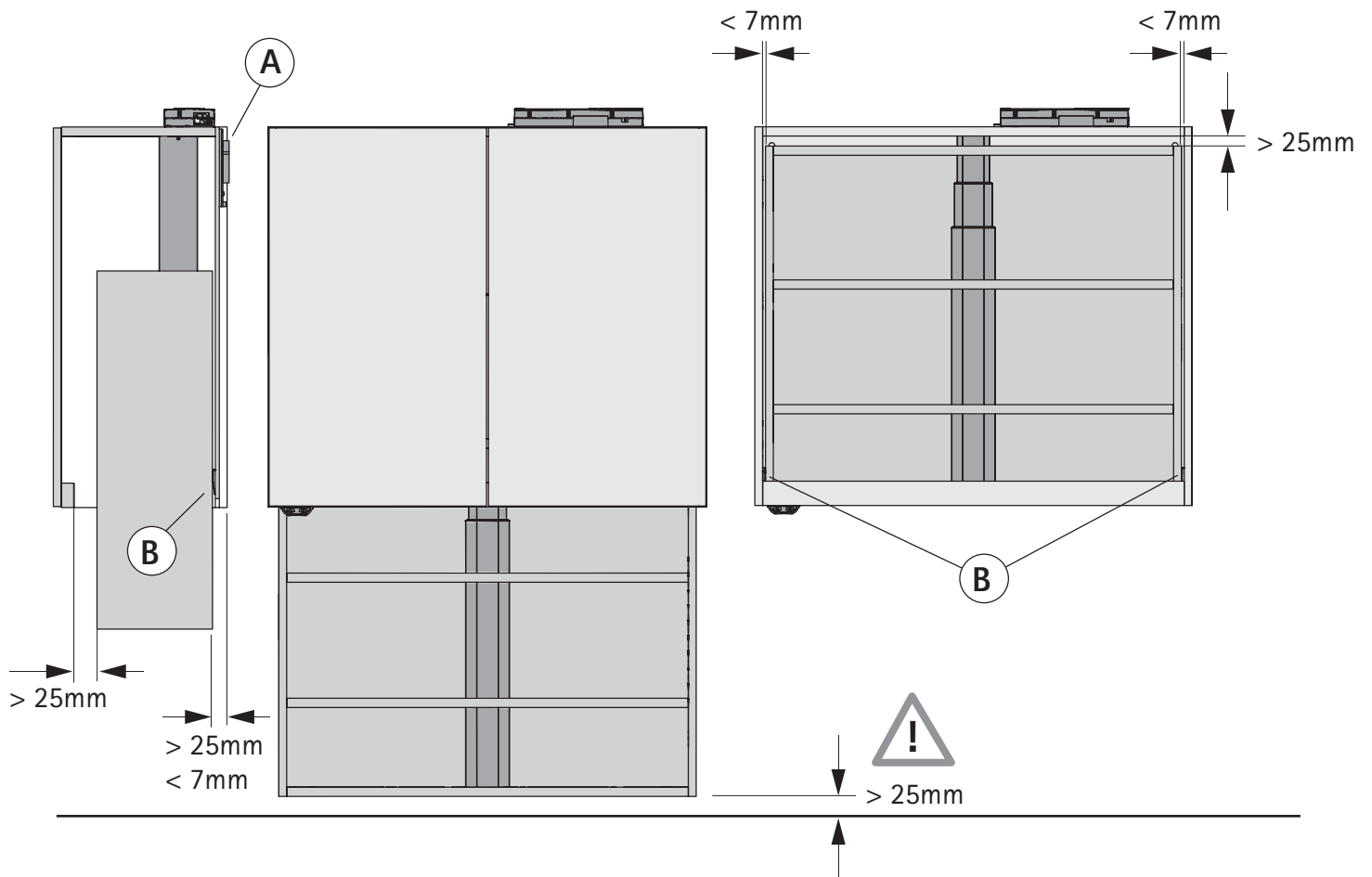
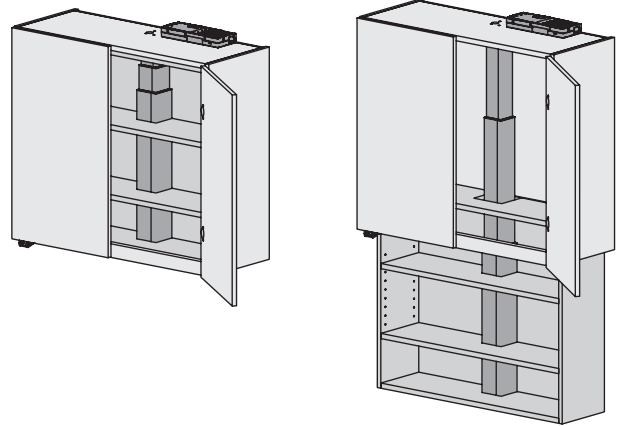

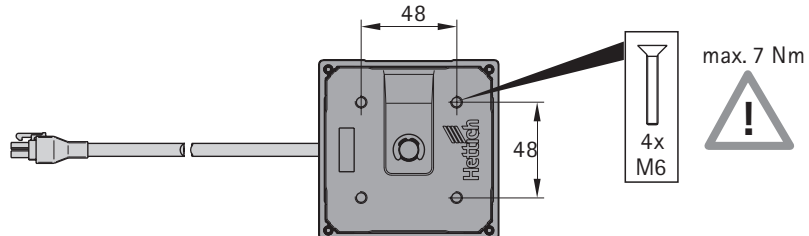
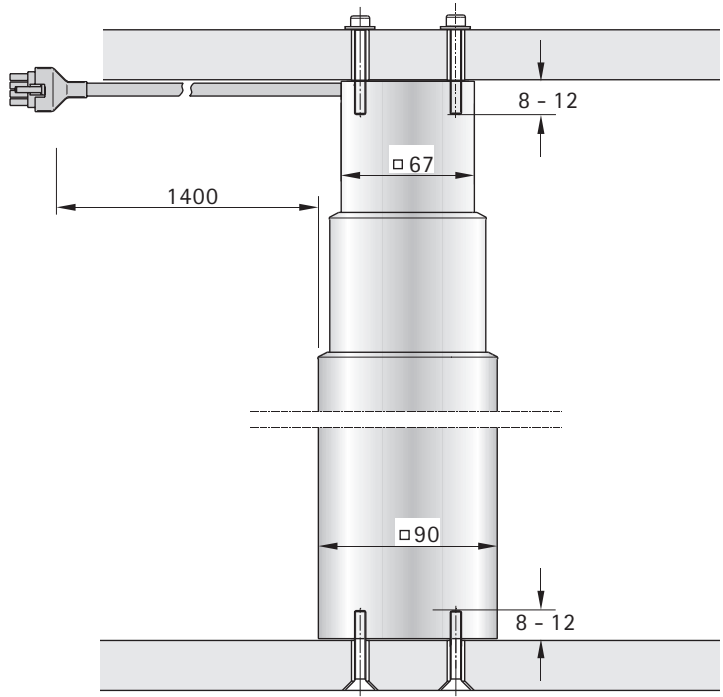
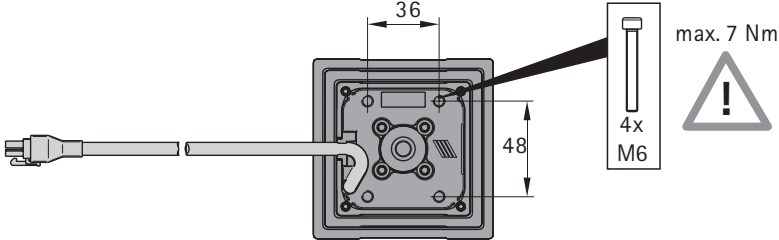
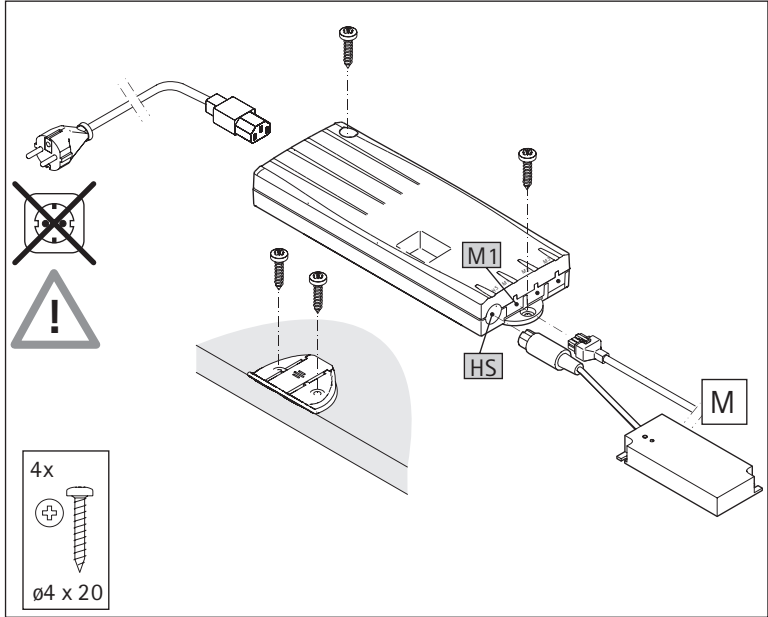
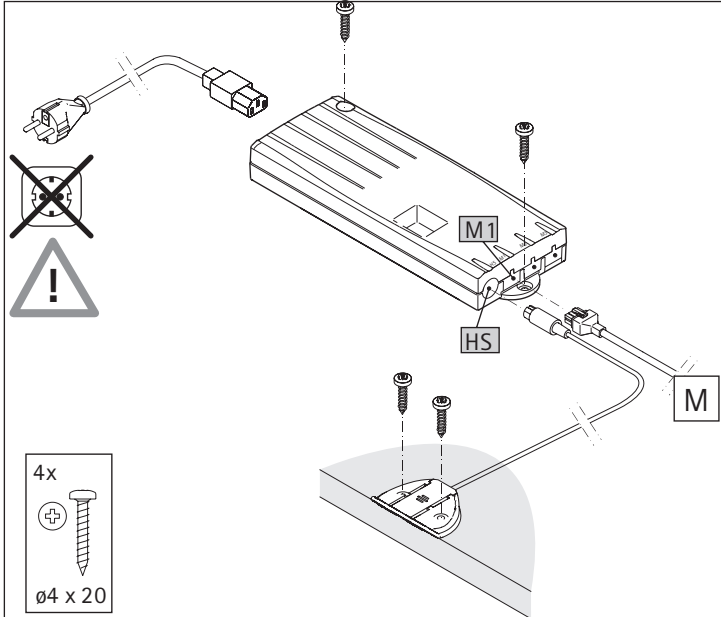

Connect to power supply

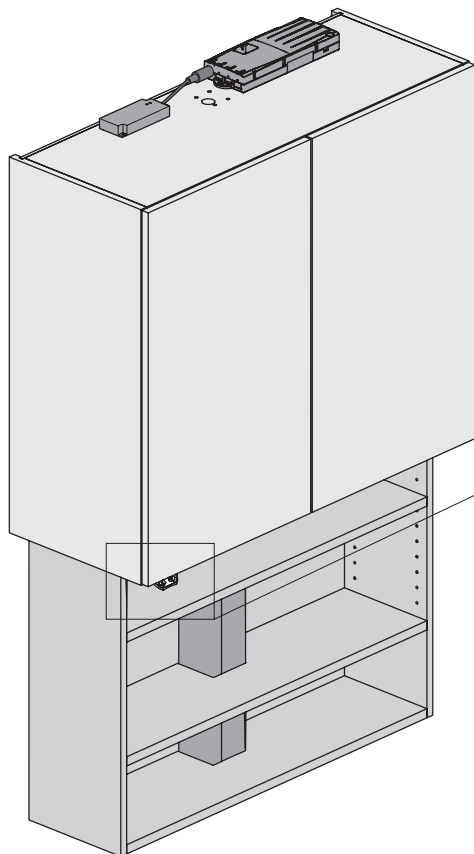
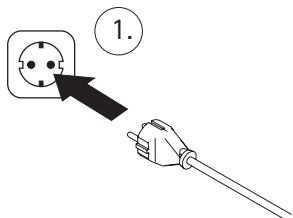

installation example

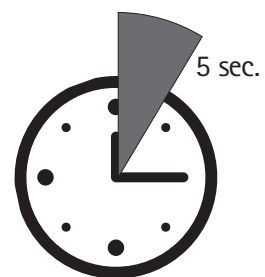
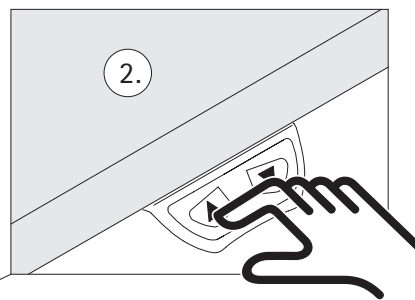

Reference run:
Keep button (for retracting the lifting column) pressed for 5 seconds.



max.
40kg*

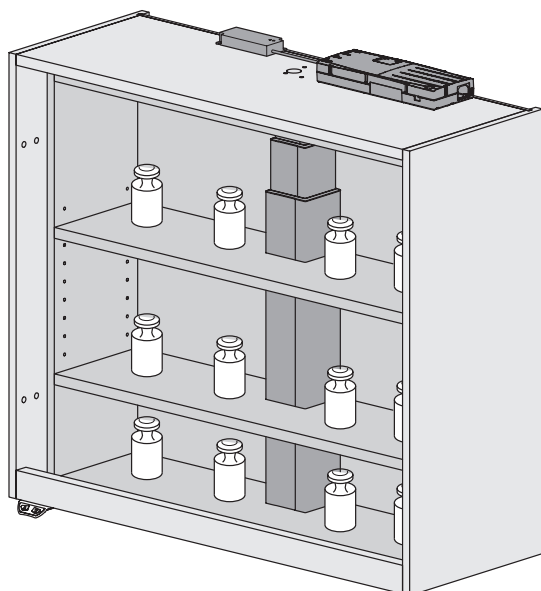

* (incl. adjustable furniture element)



1 Initial start-up

Please observe the following before starting up the LegaMove / LegaDrive lifting column system for the first time:

- Check that the LegaMove / LegaDrive lifting column system has been installed in compliance with the regulations specified above!
- Ensure that all lifting columns and handset / wireless receiver are connected to the control unit and the mains connection has been established.
- Use the documentation of the furniture manufacturer to ensure that the piece of furniture is installed properly.
- Ensure that the piece of furniture is placed on a level surface and properly aligned. For wall mounting ensure that the piece of furniture is attached and hung up according to manufacturer specifications.
- Ensure that all moving parts can move freely within the required clearance zone and that the safety distances are maintained!
- Check the proper operation of the safeguards!

2 Programming / logging off the wireless handset

The wireless receiver must be programmed (taught) to be able to understand the radiogram from the wireless handset. The teach-in procedure creates an assignment only in the wireless receiver.

The distance between the wireless handset and the wireless receiver should not exceed 0.5 m during the programming.

The wireless receiver has a „teach-in“ key (A) for programming and a „control“ LED (B) as an indicator.

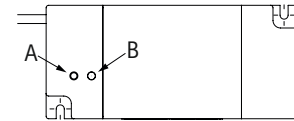

Programming

Follow the steps described below:

1. Briefly press the „teach-in“ key at the wireless receiver. The „control“ LED lights up.
2. Immediately send a radio signal (approx. 2 s) using the wireless handset. You can press the „up“ or „down“ key to send the signal. The LED switch off briefly.
3. The teach-in procedure automatically ends after approx. 8 s. When the „up“ or „down“ key of the wireless handset is pressed again, the procedure ends immediately.

Logging off

Follow the steps described below:

1. Press the "teach-in" key at the wireless receiver. The "control" LED lights up (flashes).
2. Continue to hold the key down until the LED stops flashing. This completely deletes the wireless receiver memory.

3 Reset on starting up for the first time

A reference movement must be carried out during initial start-up.



Note

The reference movement may only be carried out when the piece of furniture is unladen. Ensure that the LegaMove / LegaDrive lifting column is capable of being retracted completely as otherwise an incorrect reference position will be saved. This can result in damage to components and collisions during subsequent operation.

LegaMove

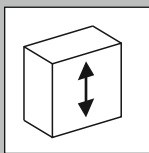

LegaDrive

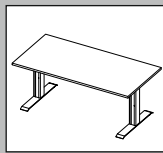

Operation instructions wireless handset

Additional information about LegaMove / LegaDrive can be found for download from the Hettich website www.hettich.com under Service / Media centre

Detailed operation instructions:



LegaMove



LegaDrive



Attention!

The **collision detection (ISP)** is not active during all reset procedures and during the end-of-travel adjustment. Pay attention to a possible risk of squashing!

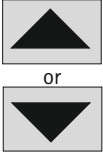

Press the arrow key for retracting the lifting column. Hold the key until the lifting column was retracted completely and the stopped in the base position. The piece of furniture can now be adjusted.

4 Top and bottom stop position

These two features can be used to limit the travel range of the LegaMove / LegaDrive lifting column system (and/or of the piece of furniture), e.g. when an obstacle is located within the travel area.

A bottom stop position can be set within the lower half of the travel; a top stop position within the top half of the travel. Once a bottom stop position has been set, it is used as the new bottom position; the top stop position corresponds to the new top position of travel. Carry out the following steps to save a bottom / top stop position:



Note

These steps must be carried out separately for a bottom stop position as well as for a top stop position!

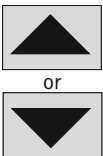
- 

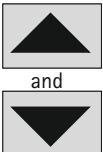
Set the LegaMove / LegaDrive lifting column system to the position that is to be defined as the bottom / top stop position. To do so, press the **lifting column system down key** or the **lifting column system up key** until the desired position is reached.
- 

Simultaneously press the **lifting column system up key** and the **lifting column system down key** and hold both keys down for approx. 10 seconds. The control unit issues a **double click** when the position is saved.

5 To disable a bottom / top stop position

Carry out the following steps to disable a bottom / top stop position:



Note

These steps must be carried out separately for a bottom stop position as well as for a top stop position!

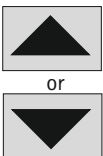
- 

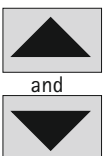
Move the LegaMove / LegaDrive lifting column system to any position within the lower half of the travel range to disable a bottom stop position, or to any position within the upper half of the travel range to disable the top stop position. To do so, press the **lifting column system down key** or the **lifting column system up key** until the desired position is reached.
- 

Simultaneously press the **lifting column system up key** and the **lifting column system down key** and hold both keys down for approx. 10 seconds. The control unit issues a **single click** when the position is disabled.

6 Manual reset

A manual reset is required after replacing of components (e.g. lifting column).



Note

The manual reset may only be carried out when the piece of furniture is unladen. Ensure that the LegaMove / LegaDrive lifting column is capable of being retracted completely as otherwise an incorrect reset position will be saved. This can result in damage to components and collisions during subsequent operation.



Attention!

The **collision detection (ISP)** is not active during all reset procedures and during the end-of-travel adjustment. Pay attention to a possible risk of squashing!

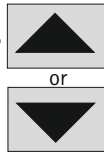
- 

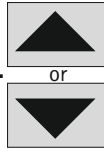
Press the arrow key for **retracting the lifting column**. Hold the key until the LegaMove / LegaDrive lifting column is retracted completely and stopped (programmed end position).
- 

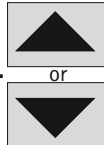
Press the relevant arrow key again and keep it pressed. After approx. 5 seconds, the lifting column is retracted further until it reaches the absolute bottom position.
- 

Release the relevant arrow key. The electrically height-adjustable piece of furniture can now be used again in the normal way.

7 Replacing the batterie

Button cell CR 2032 / 3V



Note

Immediate remove used button cells (batteries) and dispose of them in an environmentally friendly manner. They must not be discarded with household rubbish! Replace button cell with identical type only.

