

X = Schubkastenlänge
 Drawer length
 抽屉长度

Y = Mindestkorpus-tiefe
 min. cabinet depth
 最小柜内深度

*Mindestkorpus-tiefe = Schubkastenlänge + 4mm

*Min. cabinet depth = Drawer length + 4mm

*最小柜内深度=抽屉长度+4mm

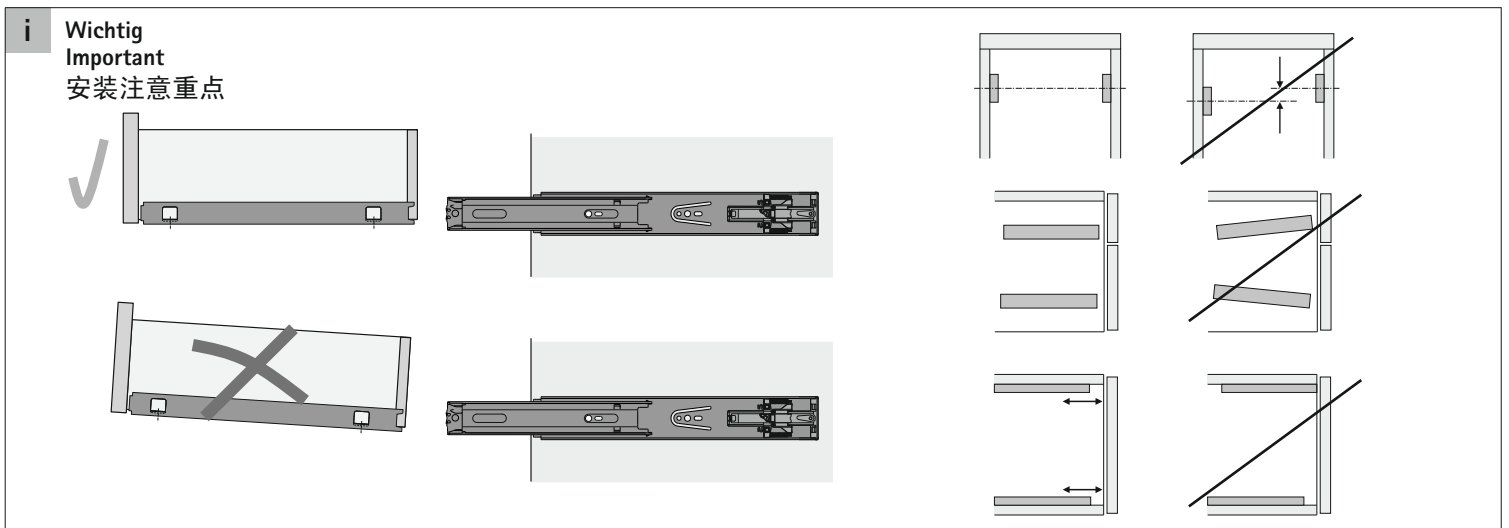
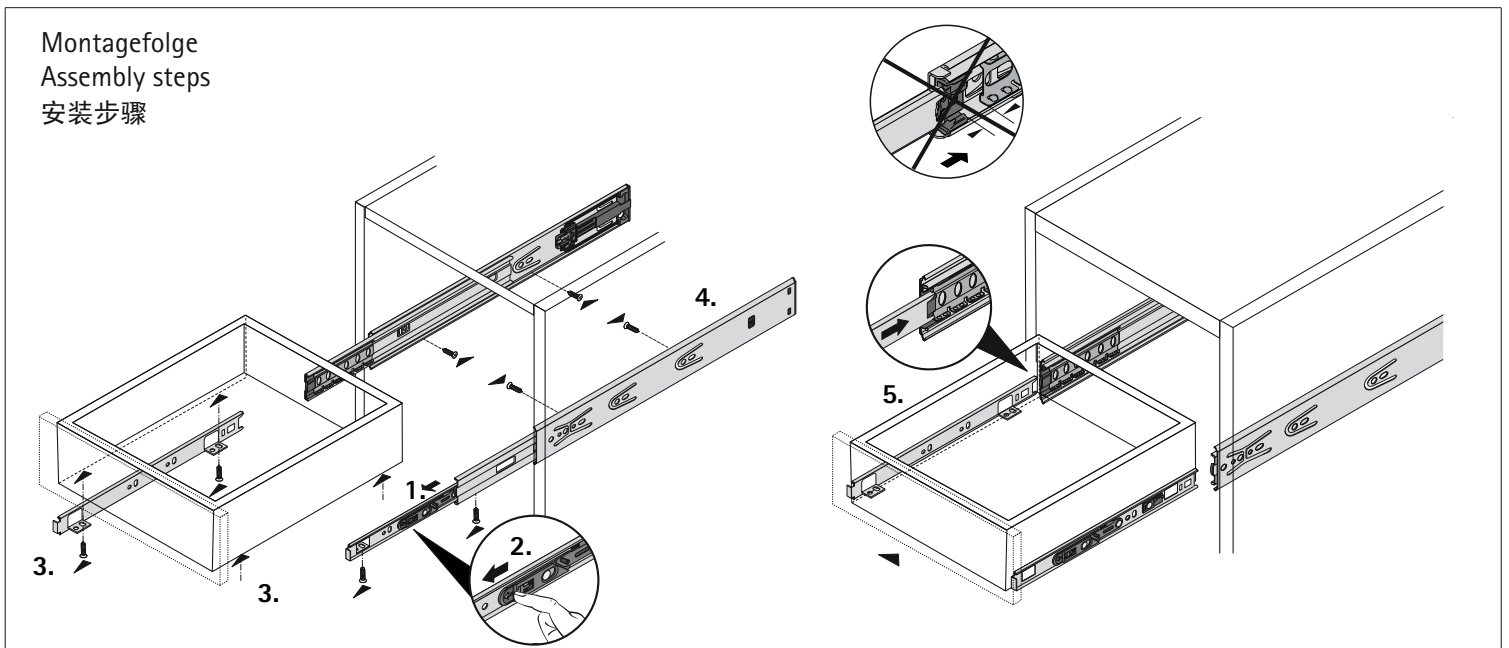
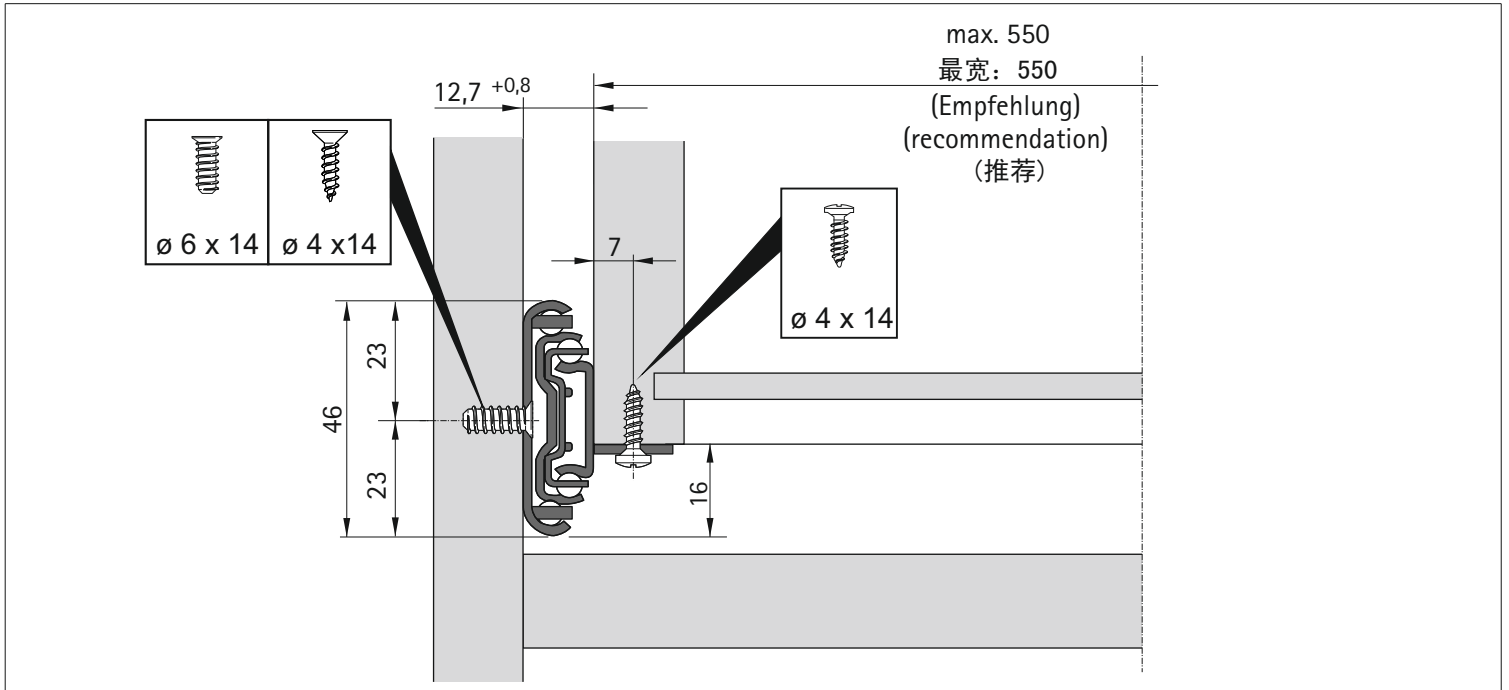

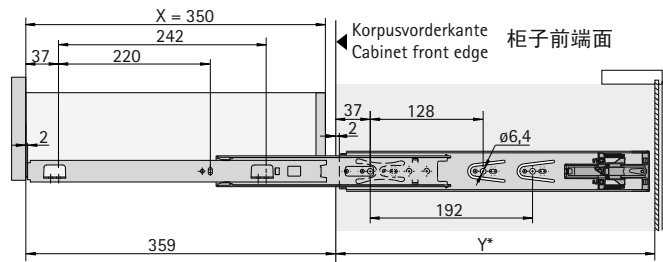

KA 4532/350

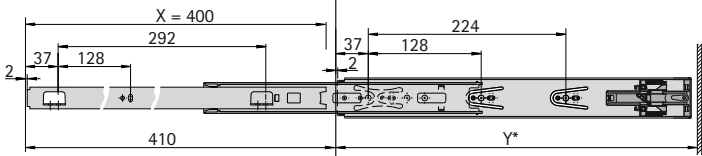

KA 4532/400

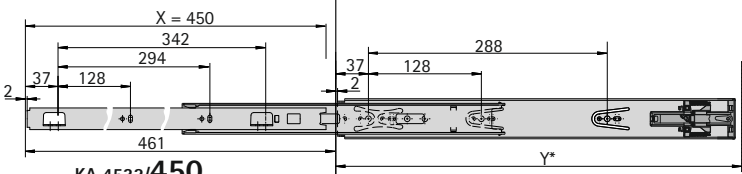

KA 4532/450

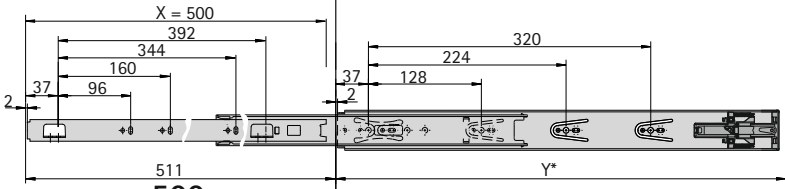

KA 4532/500

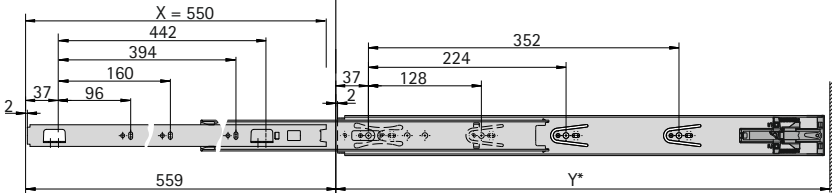

KA 4532/550

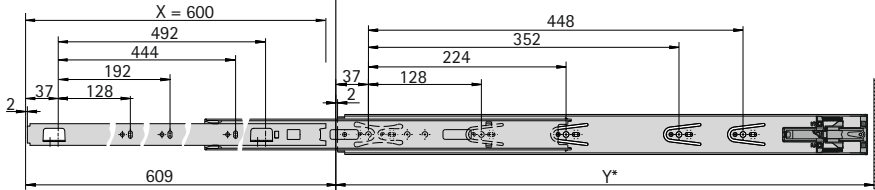

KA 4532/600

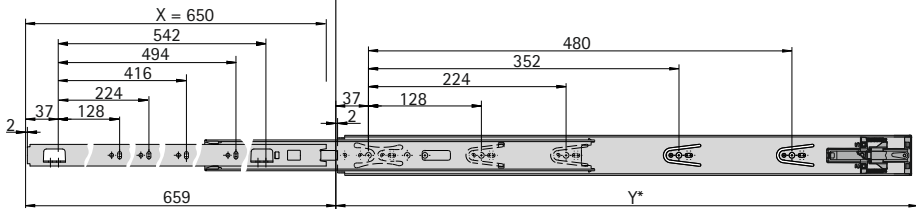

KA 4532/650

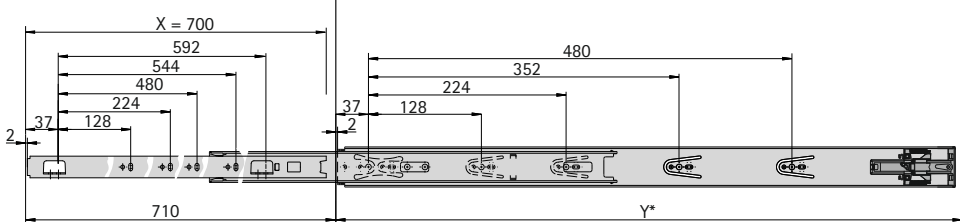

KA 4532/700

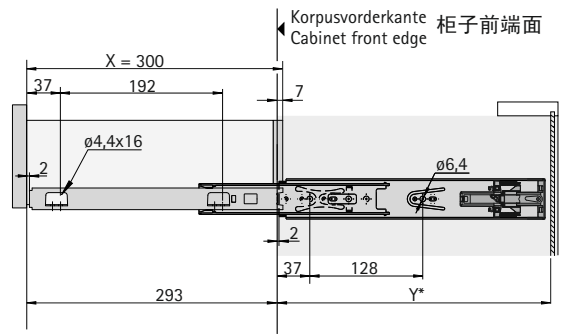

KA 4532/300

i

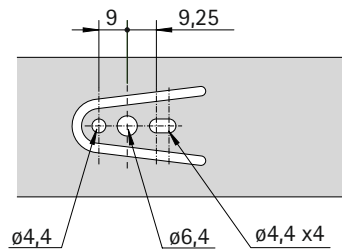
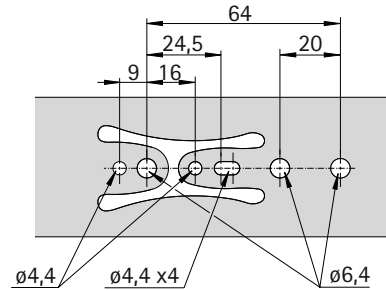
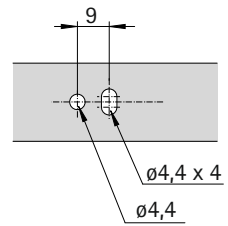

X = Schubkastenlänge
Drawer length
抽屉长度

Y = Mindestkorpus-tiefe
min. cabinet depth
最小柜内深度

*Mindestkorpus-tiefe = Schubkastenlänge + 4mm

*Min. cabinet depth = Drawer length + 4mm

*最小柜内深度=抽屉长度+4mm

