



Channelline sensor switch

Product advantages

- Switches and dims Versa lights at the touch of a button
- With built-in orientation LED

Features

- Direct installation in the Channelline profile

Application

- For Channelline C, C2, D and D2

Order information

- For single-colour Versa lights

Technical details

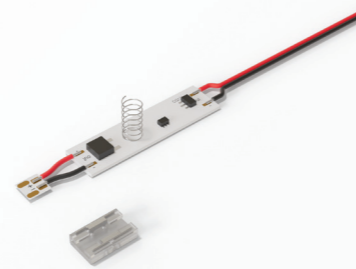

Recommended for:

- Channelline C
- Channelline C2
- Channelline D
- Channelline D2



Channelline sensor switch

Channelline sensor 12 V DC

31 051 11

Assembly drawing

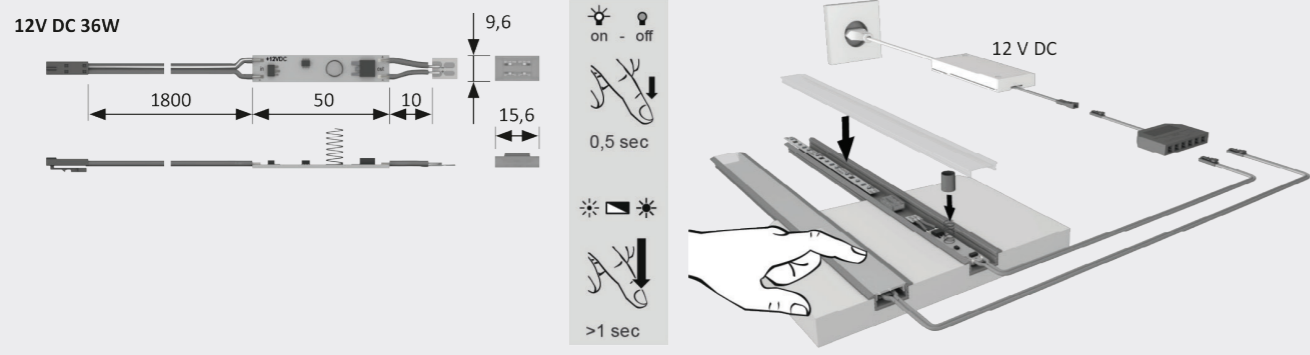

Channelline motion detector

Product advantages

- Motion sensor for insertion into the profile
- Responds to heat and movement

Features

- Direct installation in the Channelline profile
- Detection angle 120°
- Detection range 2 m
- Run-on time approx. 30 seconds

Application

- For Channelline C, C2, D and D2

Order information

- Also suitable for MultiWhite Versa

Technical details



12 V

Channelline motion detector

Channelline sensor 12 V DC

30 170 11

Recommended for:

- Channelline C
- Channelline C2
- Channelline D
- Channelline D2



Assembly drawing

